

12 Watt - LD12W Series

CONSTANT VOLTAGE OR CONSTANT CURRENT LED DRIVER



LD12W Series
12W

Model: LD12W Series

- Drive Mode: Constant Current or Constant Voltage
- Technology: PFC Off-Line Switch Mode
- Output Power: 12W Max.
- Input Voltage: 120 to 277VAC, 47- 63Hz
- Number of Outputs: One
- Output Voltages: 6VDC - 48VDC
- Output Currents: 250mA - 1000mA

Environmental

1. Operating temperature: Tc 80C Maximum. Reference -30 to +50°C ambient
2. Storage temperature range: -40 to +85°C
3. Humidity (non-condensing): 5% - 95%RH
4. Cooling: Convection
5. Vibration Frequency: 5-55Hz/2g, 30 minutes
6. Impact resistance: 1g/s
7. MTBF@ 40°C: 550,000 hours @ Full Load per MIL-217F Notice 2.

Safety and Compliance

1. UL8750, EN61347, CSA 22.2 safety compliant
2. FCC, 47CFR Part 15 Class B & EN55015 compliant.
3. Water resistant and Dust Proof Design: IP66, NEMA4, for Dry, Damp, Wet Locations.
4. Compact, Lightweight Design.
5. Safety Isolation between Primary and Secondary
6. Meets EN61000-3-2 & EN61000-3-3 Class C
7. Protection: output over-voltage, output over-current, output short circuit, auto-recovery.
8. EN61000-4-5: 2kV L-N, 8/20 µsec surge protection.

Electrical Specifications at 25°C

- Input voltage range: 120 - 277Vac (Full Range 100 to 305VAC)
- Frequency: 47- 63Hz
- Power Factor: ≥ 0.90 at $\geq 60\%$ Load 120Vac/230Vac, $\geq 70\%$ Load 277Vac
- THD: $\leq 20\%$ at $\geq 50\%$ Load, 120Vac/230Vac
- Inrush current: $<10A$ at 25C, 230V, cold start, Max. Load
- Input current: 0.12A at 120Vac, 60Hz, Maximum Load
- Efficiency: 80% typical at 120Vac 60Hz, 230Vac 50Hz
- Maximum output power: Per table below
- Line regulation accuracy: $\pm 3\%$
- Load regulation accuracy: $\pm 4\%$



IP66



Constant Current Versions

Part Number	US Class 2	CN Class 2	Output Voltage Range	Output Constant Current	Current Accuracy	Output Power Maximum	Typical Efficiency ⁽¹⁾
LD12W-48-C0250	YES	YES	24 - 48 VDC	250 mA	$\pm 3\%$	12W	80%
LD12W-36-C0350	YES	YES	18 - 36 VDC	350 mA	$\pm 3\%$	12.6W	80%
LD12W-36-C0250	YES	YES	18 - 36 VDC	250 mA	$\pm 3\%$	9W	77%
LD12W-24-C0500 ⁽²⁾	YES	YES	12 - 24 VDC	500 mA	$\pm 3\%$	12W	78%
LD12W-16-C0800	YES	YES	8 - 16 VDC	800 mA	$\pm 3\%$	12.8W	78%
LD12W-16-C0700	YES	YES	8 - 16 VDC	700 mA	$\pm 3\%$	11.2W	78%
LD12W-12-C1000 ⁽²⁾	YES	YES	6 - 12 VDC	1000 mA	$\pm 3\%$	12W	77%

Constant Voltage Versions

Part Number	US Class 2	CN Class 2	Output Voltage	Output Current Range	Voltage Accuracy	Output Power Maximum	Typical Efficiency ⁽¹⁾
LD12W-48	YES	YES	48 VDC	63 - 250 mA	$\pm 5\%$	12W	80%
LD12W-36	YES	YES	36 VDC	88 - 350 mA	$\pm 5\%$	12.6W	80%
LD12W-24 ⁽²⁾	YES	YES	24 VDC	125 - 500 mA	$\pm 5\%$	12W	78%
LD12W-16	YES	YES	16 VDC	200 - 800 mA	$\pm 5\%$	12.8W	78%
LD12W-12 ⁽²⁾	YES	YES	12 VDC	250 - 1000 mA	$\pm 5\%$	12W	77%

Notes

1. Typical efficiency measured at 230VAC input, full load.
2. SAM Recognized

12 Watt - LD12W Series

CONSTANT VOLTAGE OR CONSTANT CURRENT LED DRIVER

Mechanical Dimensions: Inches [mm]

Material: Black PC ABS Plastic Case
Fully Encapsulated
Weight: 128 grams (4.5 oz) Typical

Labeling Example

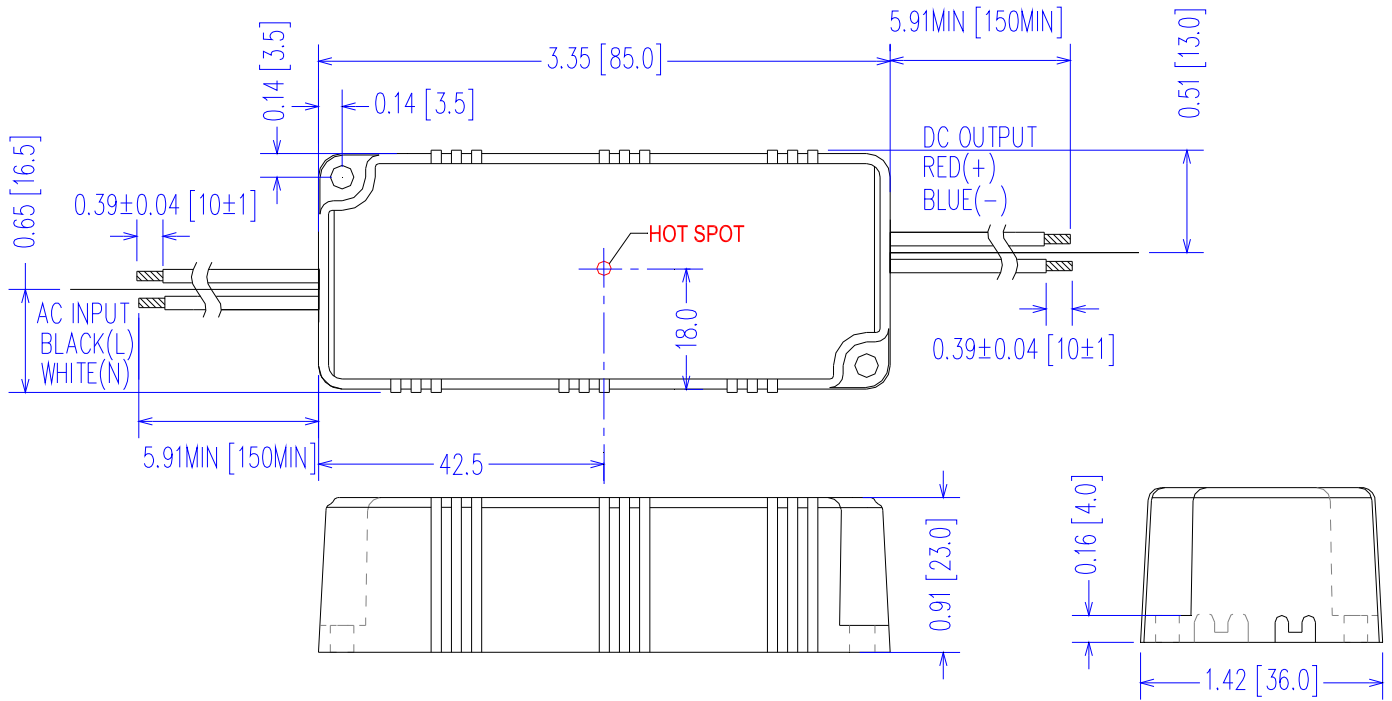

12 Watt - LD12W Series

CONSTANT VOLTAGE OR CONSTANT CURRENT LED DRIVER

LD12W Series
12W

Input Specifications

Parameter	Min.	Typ.	Max.	Notes/Conditions
Input Voltage	100 Vac	—	305 Vac	120, 230, 240, 277 Vac Nominal Values
Input Frequency	47 Hz	—	63 Hz	50/60Hz Nominal
Input AC Current	—	—	0.13A	Measured at 120Vac/60Hz Input, Output Full load.
	—	—	0.07A	Measured at 230Vac/50Hz Input, Output Full load.
	—	—	0.06A	Measured at 277Vac/60Hz Input, Output Full load.
Inrush Current (Peak)	—	—	10A	Measured at 277Vac/60Hz Input, Output Full Load, Ta 25°C, Cold Start 50% Ipeak duration ~750 µsec (1/2*I _p ² *t)
Inrush Current (I ² t)	—	—	0.04 A ² s	
Leakage Current	—	0.36mA	0.50mA	Measured at 120Vac/60Hz Input, Output Full load.
	—	0.61mA	0.75mA	Measured at 277Vac/60Hz Input, Output Full load.
THD	—	—	20%	THD%: ≤ 20% at ≥ 50% Load, 120Vac/230Vac
Power Factor (PF)	0.90	—	—	PF: ≥ 0.90 at ≥ 60% Load 120Vac/230Vac, ≥ 70% Load 277Vac

Output Specifications

Parameter	Min.	Typ.	Max.	Notes/Conditions
DC Output Voltage	Per Table	—	Per Table	Per Tables on Page 1
DC Output Constant Current	-4%	Per Table	+4%	Per Tables on Page 1
Output Power	—	—	Per Table	Per Tables on Page 1
Ripple & Noise (Vpk-pk)	—	—	20% Vo	20 MHz BW, Full load output in parallel with 0.1 µF ceramic & 10 µF Electrolytic.
Ripple (Ipk-pk)	—	—	50% Io	20 MHz BW, Full load output in parallel with 0.1 µF ceramic & 10 µF Electrolytic. 120 Hz component
Start-up Time	—	700 mS	1000 mS	Measured at 120Vac/60Hz Input, Output Full load.
Hold-up Time	—	30 mS	—	Typical @ 277Vac Input, Output Full load.

Environmental Specifications

Parameter	Min.	Typ.	Max.	Notes/Conditions
Case Temperature (Tc)	-30 °C	—	+80 °C	Measured at location specified on case.
Operating Temperature (Ta)	-30 °C	—	+50 °C	This is a reference range. Tc controls temperature range.
Storage Temperature (Ts)	-40 °C	—	+85 °C	Non operating temperature range.
Operating Humidity	—	—	95% RH	Relative Humidity, non-condensing.
Vibration	5 Hz	—	55 Hz	2G, 10 minutes/1 cycle, period 30 minutes, each along X, Y, Z axis.
MTBF	482,000 Hours	—	—	MIL-HDBK-217F Notice 2, Ta = 25C, Output Full Load.

Protection Specifications

Parameter	Min.	Typ.	Max.	Notes/Conditions
Output Short Circuit (SCP)	—	—	—	No Damage, Auto recovery after short is removed.
Output Over Current (OCP)	—	—	+8% Io	Constant Current Limiting circuit.
Output Over Voltage (OVP)	—	—	120% Vo	No Damage, Auto recovery after fault is removed.

12 Watt - LD12W Series

CONSTANT VOLTAGE OR CONSTANT CURRENT LED DRIVER

Safety Compliance

Safety	Notes/Standards
UL/CUL	UL8750, UL1310 for UL Class 2 & CAN/CSA C22.2 No. 250.13
CE	EN61347-1, EN61347-2-13
Withstand Voltage	Input to Output: 3750 Vac
Isolation Resistance	Input to Output: >100 MΩ, 500VDC @ 25 °C, 70 % RH

EMC Compliance

Standard	Notes/Conditions
FCC, 47CFR Part 15	Class B
EN 55015	Limits and methods of measurement of radio disturbance characteristics of electrical lighting and similar equipment.
EN 61000-3-2	Part 3-2: Limits for harmonic current emissions Class C, $\geq 80\%$ Rated Power
EN 61000-3-3	Part 3-3: Limitation of voltage changes, voltage fluctuations and flicker.
EN 61000-4-5	Part 4-5: Surge Immunity test, 2 kV L-N
Energy Star	Energy Star transient protection: Ballast or driver shall comply with ANSI/IEEE C62.41.1-2002 and ANSI/IEEE C62.41.2-2002, Category A operation. The line transient shall consist of seven strikes of a 100 kHz ring wave, 2.5 kV level, for both common mode and differential mode.

Power Factor Curves (Typical)

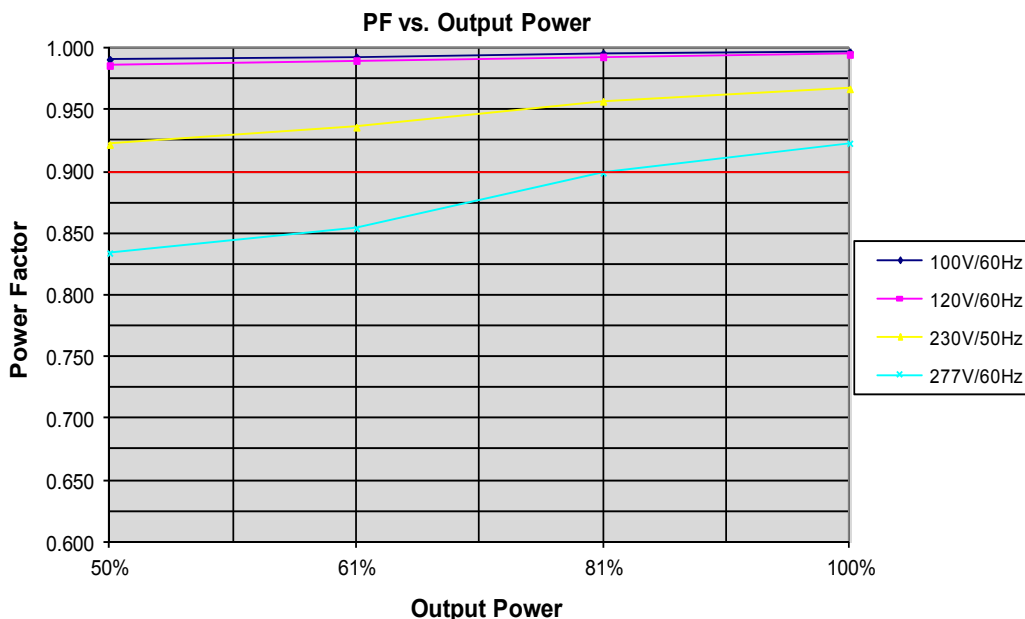

12 Watt - LD12W Series

CONSTANT VOLTAGE OR CONSTANT CURRENT LED DRIVER

12W
LD12W Series

THD Curves (Typical)

THD vs. Output Power

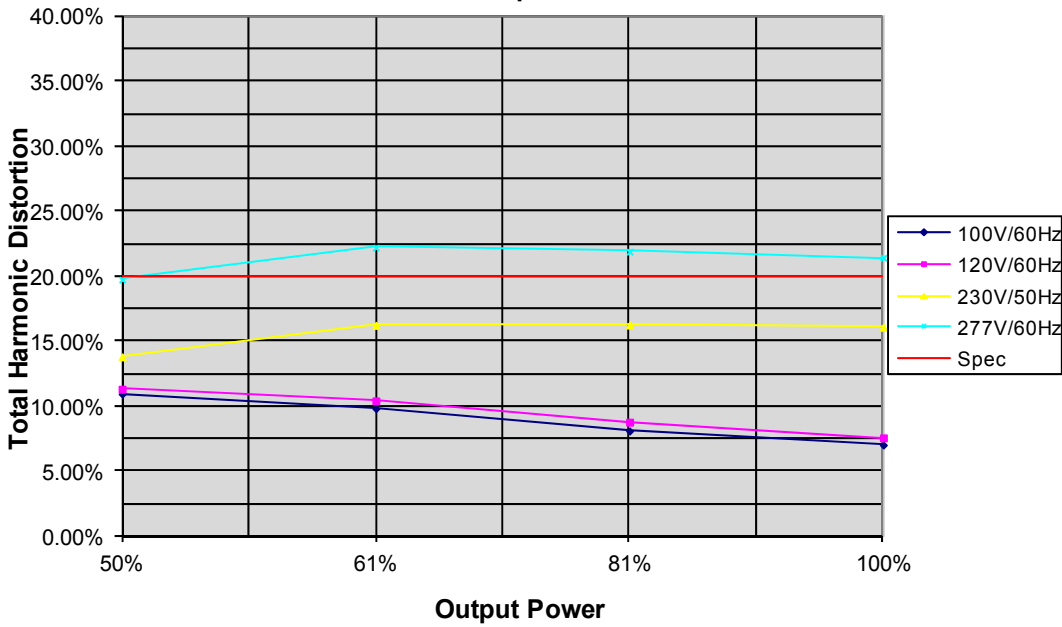

Efficiency Curve (Typical)

Efficiency vs. Output Power

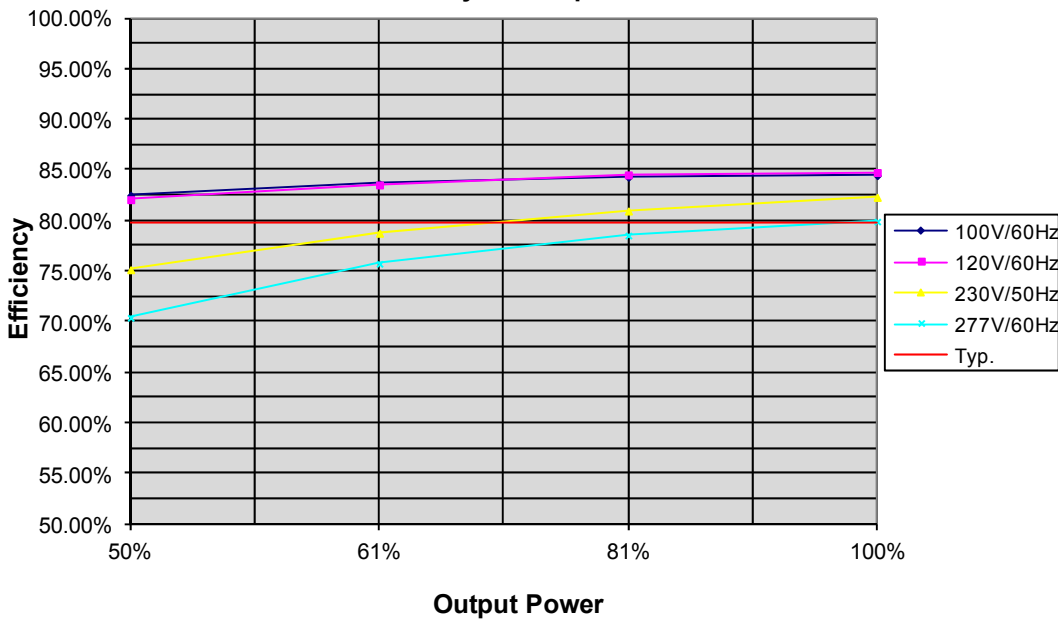

12 Watt - LD12W Series

CONSTANT VOLTAGE OR CONSTANT CURRENT LED DRIVER

Life vs. Ambient Temperature

LD12W Estimated Life Full Load @ 120Vac

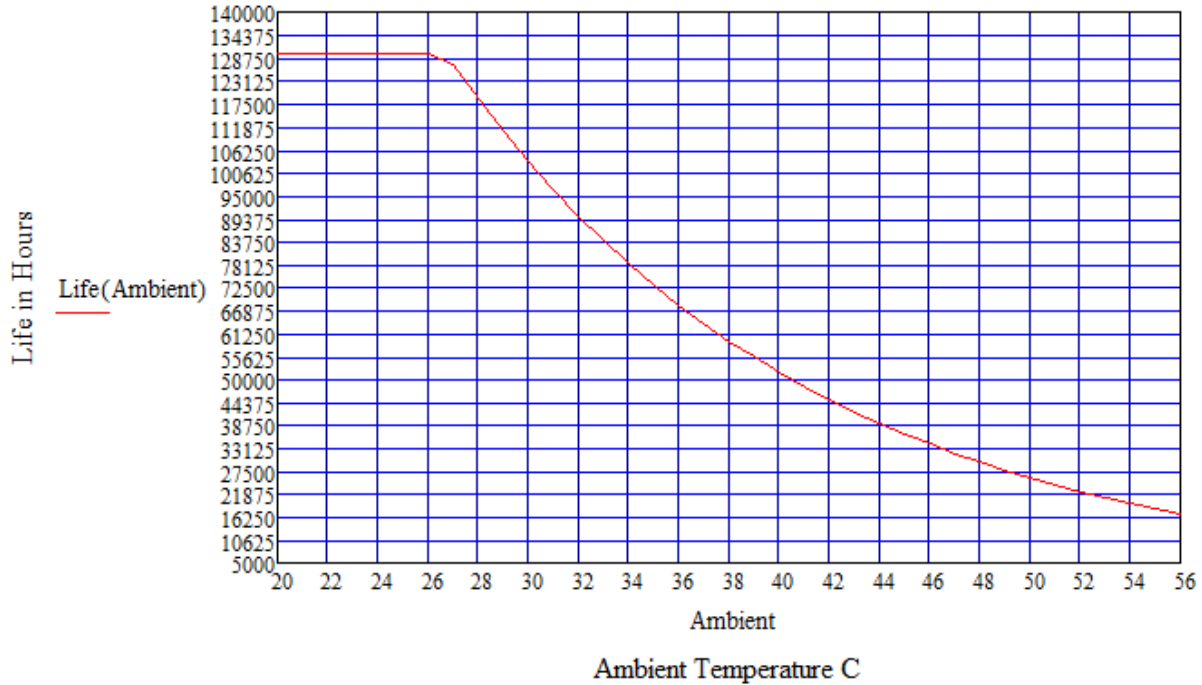

Life vs. Case (Tc) Temperature

LD12W Estimated Life Full Load @ 120Vac

