

40 Watt - LDHL40W Series

CONSTANT CURRENT LED DRIVER FOR HAZARDOUS LOCATIONS



40W
 LDHL40W Series
 UL TYPE HL

Model: LDHL40W Series

- Drive Mode: Constant Current or Constant Voltage
- Output Power: 40W Max.
- Input Voltage: 90 to 305VAC, 47- 63Hz
- Number of Outputs: One
- Output Voltages: 3VDC - 130VDC
- Output Currents: 300mA - 4450mA
- Optional 0-10V or PWM Positive Dimming 10% ~ 100%
- UL Type HL Rated for Hazardous Locations

Environmental

1. Operating temperature: Tc 90C Maximum. Reference -30 to +60°C ambient
2. Storage temperature range: -40 to +85°C
3. Humidity (non-condensing): 5% - 95%RH
4. Cooling: Convection
5. Vibration Frequency: 5-55Hz/2g, 30 minutes
6. Impact resistance: 1g/s
7. MTBF @ 40°C: 482,000 hours @ Full Load per MIL-217F Notice 2.

Safety and Compliance

1. UL8750, EN61347, CSA 22.2 safety recognized, UL Type HL
2. FCC, 47CFR Part 15 Class B & EN55015 compliant.
3. Water resistant and Dust Proof Design: IP66, NEMA4, for Dry, Damp, Wet Locations.
4. Compact, Lightweight Design using 5VA rated case.
5. Safety Isolation between Primary and Secondary
6. Protection: output over-voltage, output over-current, output short circuit, auto-recovery.
7. Internal Thermal protection. Hick-up mode.
Off if Tc reaches $\approx 105\text{C}$, On when Tc reaches $\approx 65\text{C}$

Electrical Specifications at 25°C

- Input voltage range: 90 to 305VAC
- Frequency: 47- 63HZ
- Power Factor: ≥ 0.90 at $\geq 60\%$ Load, 120Vac/230Vac, $\geq 85\%$ Load 277Vac
- THD%: $\leq 20\%$ at $\geq 60\%$ Load, 120Vac/230Vac/277Vac, $\geq 80\%$ Load 277Vac
- Inrush current: $<20\text{A}$ at 25C, 230V, cold start, Full Load
- Input current: 0.42A typical at 120Vac, 60Hz, Full Load
- Efficiency: 85% typical at 230Vac Full Load
- Constant Current regulation: $\pm 3\%$ Over Input Line Variation
- Load regulation accuracy: $\pm 4\%$
- Leakage current: 400uA typical; Hold up time: half cycle

Constant Current Versions



IP66



Part Number ⁽²⁾	US Class 2	CN Class 2	Output Voltage Range	Output Constant Current	Current Accuracy	Output Power Maximum	Typical Efficiency ⁽¹⁾
LDHL40W-130-C0300	NO	NO	44 - 130 VDC	300 mA	$\pm 3\%$	40W	87%
LDHL40W-114-C0350	NO	NO	38 - 114 VDC	350 mA	$\pm 3\%$	40W	86%
LDHL40W-100-C0400	NO	NO	33 - 100 VDC	400 mA	$\pm 3\%$	40W	86%
LDHL40W-89-C0450	NO	NO	30 - 89 VDC	450 mA	$\pm 3\%$	40W	86%
LDHL40W-72-C0550	NO	NO	24 - 72 VDC	550 mA	$\pm 3\%$	40W	85%
LDHL40W-54-C0700	YES	NO	18 - 54 VDC	700 mA	$\pm 3\%$	38W	85%
LDHL40W-48-C0830	YES	NO	16 - 48 VDC	830 mA	$\pm 3\%$	40W	85%
LDHL40W-45-C0900	YES	NO	16 - 45 VDC	900 mA	$\pm 3\%$	40W	85%
LDHL40W-40-C1000	YES	YES	13 - 40 VDC	1000 mA	$\pm 3\%$	40W	85%
LDHL40W-36-C1100	YES	YES	12 - 36 VDC	1100 mA	$\pm 3\%$	40W	85%
LDHL40W-30-C1400	YES	YES	10 - 30 VDC	1400 mA	$\pm 3\%$	42W	85%
LDHL40W-24-C1670 ⁽⁵⁾	YES	YES	8 - 24 VDC	1670 mA	$\pm 3\%$	40W	85%
LDHL40W-22-C1820	YES	YES	7 - 22 VDC	1820 mA	$\pm 3\%$	40W	85%
LDHL40W-18-C2200	YES	YES	6 - 18 VDC	2200 mA	$\pm 3\%$	40W	84%
LDHL40W-15-C2680	YES	YES	5 - 15 VDC	2680 mA	$\pm 3\%$	40W	84%
LDHL40W-13-C3080	YES	YES	4 - 13 VDC	3080 mA	$\pm 3\%$	40W	84%
LDHL40W-12-C3330 ⁽⁵⁾	YES	YES	4 - 12 VDC	3330 mA	$\pm 3\%$	40W	83%
LDHL40W-10-C4000	YES	YES	3 - 10 VDC	4000 mA	$\pm 3\%$	40W	83%
LDHL40W-09-C4450	YES	YES	3 - 9 VDC	4450 mA	$\pm 3\%$	40W	82%

- Notes**
1. Typical efficiency measured at 230VAC input, full load
 2. For dimmable versions add appropriate designator to the end of the part number: For Example: LDHL40W-18-C2200-RD is 0-10V or resistance dimmable version, LDHL40W-18-C2200-PD is PWM dimmable version.
-RD 0-10V & Resistance dimmable version comes with an extra two wires +Purple/-Grey on the output side.
-PD PWM Dimmable version comes with an extra two wires +Purple/-Grey on the output side.
 3. -RD 0-10V Dimming is compatible with most quality 0-10V wall dimmers and direct 0-10V analog signal. See page 3 for details.
 4. -PD PWM version is PWM Dimmable via a positive 10% to 100% Duty Cycle, 500Hz to 1.5KHz, 0-10V Pulse. See page 4 for details.
 5. SAM Recognized.

40 Watt - LDHL40W Series

CONSTANT CURRENT LED DRIVER FOR HAZARDOUS LOCATIONS

Constant Voltage Versions

Part Number	US Class 2	CN Class 2	Output Constant Voltage	Output Current Range	Voltage Accuracy	Output Power Maximum	Typical Efficiency ⁽¹⁾
LDHL40W-130	NO	NO	130 VDC	75 - 300 mA	± 5%	40W	87%
LDHL40W-114	NO	NO	114 VDC	75 - 350 mA	± 5%	40W	86%
LDHL40W-100	NO	NO	100 VDC	100 - 400 mA	± 5%	40W	86%
LDHL40W-89	NO	NO	89 VDC	113 - 450 mA	± 5%	40W	86%
LDHL40W-72	NO	NO	72 VDC	138 - 550 mA	± 5%	40W	85%
LDHL40W-54	YES	NO	54 VDC	175 - 700 mA	± 5%	38W	85%
LDHL40W-48	YES	NO	48 VDC	208 - 830 mA	± 5%	40W	85%
LDHL40W-45	YES	NO	45 VDC	225 - 900 mA	± 5%	40W	85%
LDHL40W-40	YES	YES	40 VDC	250 - 1000 mA	± 5%	40W	85%
LDHL40W-36	YES	YES	36 VDC	275 - 1100 mA	± 5%	40W	85%
LDHL40W-30	YES	YES	30 VDC	350 - 1400 mA	± 5%	42W	85%
LDHL40W-24 ⁽⁵⁾	YES	YES	24 VDC	418 - 1670 mA	± 5%	40W	85%
LDHL40W-22	YES	YES	22 VDC	455 - 1820 mA	± 5%	40W	85%
LDHL40W-18	YES	YES	18 VDC	550 - 2200 mA	± 5%	40W	84%
LDHL40W-15	YES	YES	15 VDC	670 - 2680 mA	± 5%	40W	84%
LDHL40W-13	YES	YES	13 VDC	770 - 3080 mA	± 5%	40W	84%
LDHL40W-12 ⁽⁵⁾	YES	YES	12 VDC	825 - 3330 mA	± 5%	40W	83%
LDHL40W-10	YES	YES	10 VDC	1000 - 4000 mA	± 5%	40W	83%
LDHL40W-09	YES	YES	9 VDC	1113 - 4450 mA	± 5%	40W	82%

Mechanical Dimensions: Inches [mm]

Material: Black 5VA Plastic Case
Fully Encapsulated
Weight: 364 grams (12.9 oz) Typical

STANDARD LEAD-OUTS ARE FROM BOTTOM

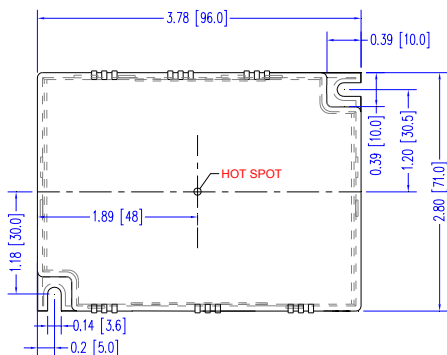

ALTERNATE LEAD-OUTS FROM SIDES

For Example:
LDHL40W-36-C1100-SE is non dimmable version
LDHL40W-36-C1100-RDSE is 0-10V dimmable version
LDHL40W-36-C1100-PDSE is PWM dimmable version

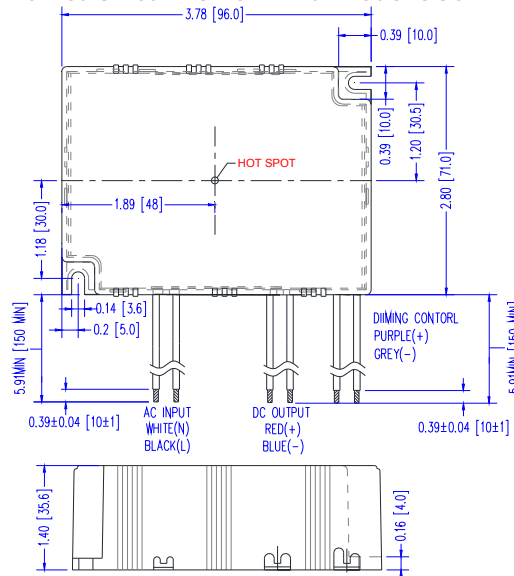

Labeling Example

LED Optimized Driver
EPtronics, Inc. www.EPtronics.com 800-643-0688/310-433-0700

Part Number: LDHL40W-54-C0700-RD
Input Voltage: 90-305 VAC 50/60Hz
Input Current: 0.56 Amp Max
Output Voltage: 18-54 VDC
Output Current: 700 mA Constant Current
Output Power: 40W Max
0-10V CCR Dimmable Output
UL & cUL Class 2 Output, UL Type HL

IP66

Made in China E325626 REV E1.2 HG

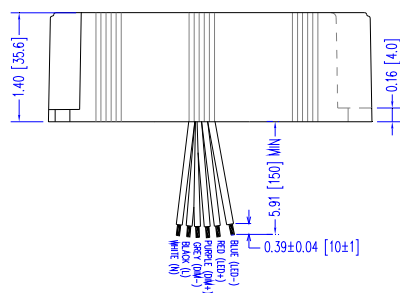

40 Watt - LDHL40W Series

CONSTANT CURRENT LED DRIVER FOR HAZARDOUS LOCATIONS

UL TYPE HL
 LDHL40W Series
40W

-RD 2-Wire 0-10V CCR Dimming Scheme

Parameters	Minimum	Typical	Maximum
Source Current out of 0-10V Purple Wire	0mA	—	2mA
Absolute Voltage Range on 0-10V (+) Purple Wire	-2.0V	—	+15V
Sink Current into 0-10V Purple Wire	0mA	—	1.2mA

Notes

- RD 0-10V dimmable version comes with an extra two wires +Purple/-Grey on the output side.
- RD version is compatible with most 0-10V Wall Slide dimmers and direct 0-10V analog signal.
Recommended wall slide dimmer is Leviton IP710 or equivalent
- RD 0-10V dimmable version is not intended to dim below about 5% @ 0V or 10% @ 1.0V
- RD 0-10V dimmable version output will be 100% with Purple/Grey open and minimum with Purple/Grey Shorted.

-RD 2-Wire Resistance Dimming Scheme

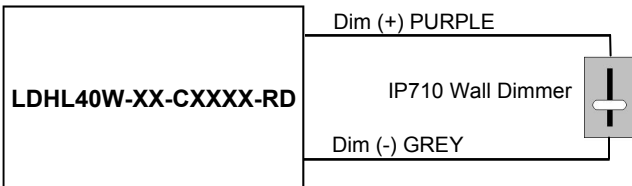

-RD 2-Wire 0-10V Analog Dimming Scheme

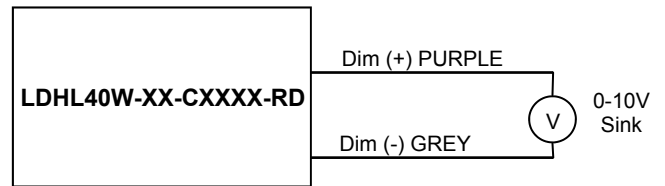

% Output Current vs. 0-10VDC Dimming Input

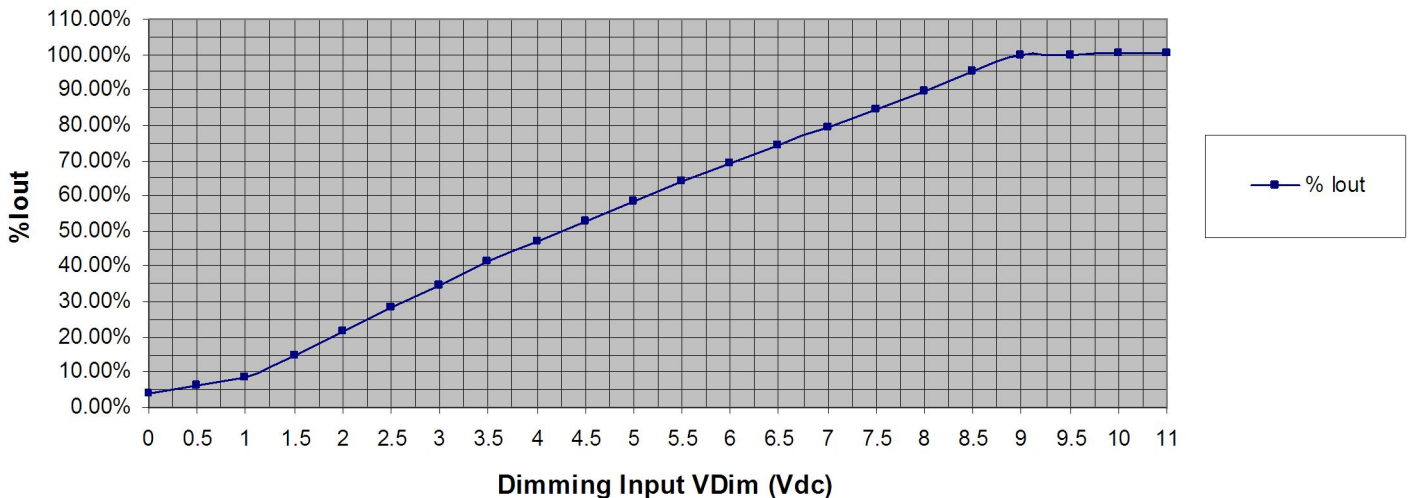

40 Watt - LDHL40W Series

CONSTANT CURRENT LED DRIVER FOR HAZARDOUS LOCATIONS

-PD 2-Wire CCR PWM Positive Dimming Scheme

Parameters	Minimum	Typical	Maximum
Absolute Maximum Voltage Range on PWM Input (Purple Wire)	-2.0V	10V	+15V
Input LOW Level Voltage Range (Purple Wire)	-2.0V	0V	+5.5V
Input HIGH Level Voltage Range (Purple Wire)	+9.0V	10V	+15V
Current into PWM Input (Purple Wire)	0mA	—	1.2mA
Source Current out of PWM Input (Purple Wire)	0mA	—	2mA
PWM Input Signal Frequency	500Hz	—	1500Hz
PWM Input Signal Positive Duty Cycle	0%	10-90%	100%

Notes

1. -PD PWM Dimmable version comes with an extra 2 wires +Purple/-Grey on the output side.
2. -PD PWM Dimmable version is not intended to dim below about 5% @ 0% Duty Cycle or 10% @ 10% Duty Cycle
3. -PD PWM dimmable version output will be 100% with Purple/Grey open and minimum with Purple/Grey Shorted.

-PD 2-Wire PWM Positive Dimming Scheme

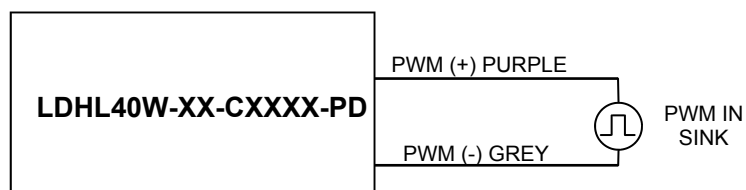

% Output Current vs. 1.0 kHz, Positive Duty Cycle Dimming Input

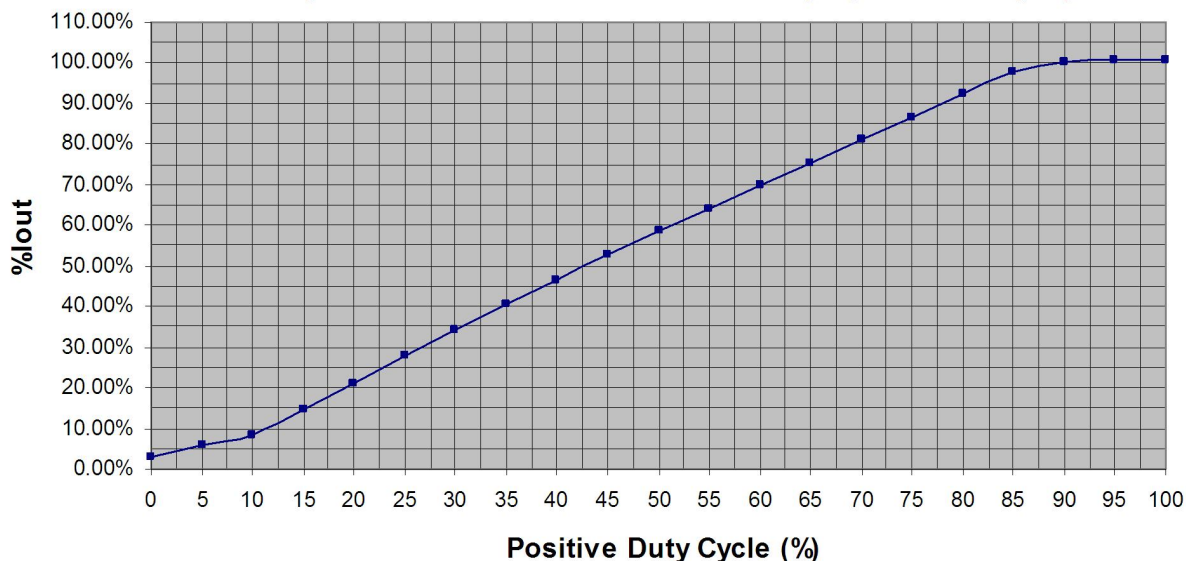

40 Watt - LDHL40W Series

CONSTANT CURRENT LED DRIVER FOR HAZARDOUS LOCATIONS

UL TYPE HL
 LDHL40W Series
40W

Input Specifications

Parameter	Min.	Typ.	Max.	Notes/Conditions
Input Voltage	90 Vac	—	305 Vac	120, 230, 240, 277 Vac Nominal Values
Input Frequency	47 Hz	—	63 Hz	50/60Hz Nominal
Input AC Current	—	—	0.42 A	Measured at 120Vac/60Hz Input, Output Full load.
	—	—	0.22 A	Measured at 230Vac/60Hz Input, Output Full load.
	—	—	0.19 A	Measured at 277Vac/60Hz Input, Output Full load.
Inrush Current (Peak)	—	14A	20A	Measured at 277Vac/60Hz Input, Output Full Load, Ta 25°C, Cold Start 50% I _{peak} duration \approx 750 μ sec (1/2*I _p ² *t)
Inrush Current (I ² t)	—	—	0.15 A ² s	
Leakage Current	—	—	0.28mA	Measured at 120Vac/60Hz Input, Output Full load.
	—	—	0.75mA	Measured at 277Vac/60Hz Input, Output Full load.
THD	—	—	20%	Measured at \geq 60% Load, 120Vac/230Vac, \geq 80% Load 277Vac
Power Factor (PF)	0.90	—	—	Measured at \geq 60% Load, 120Vac/230Vac, \geq 85% Load 277Vac

Output Specifications

Parameter	Min.	Typ.	Max.	Notes/Conditions
DC Output Voltage	Per Table	—	Per Table	Per Tables on Page 1
DC Output Constant Current	-3%	Per Table	+3%	Per Tables on Page 1
Output Power	—	—	Per Table	Per Tables on Page 1
Ripple & Noise (V _{pk-pk})	—	—	20% V _o	20 MHz BW, Full load output in parallel with 0.1 μ F ceramic & 10 μ F Electrolytic.
Ripple (I _{pk-pk})	—	—	50% I _o	20 MHz BW, Full load output in parallel with 0.1 μ F ceramic & 10 μ F Electrolytic. 120 Hz component (Flicker Free)
Start-up Time	—	700 mS	1000 mS	Measured at 120Vac/60Hz Input, Output Full load.
Hold-up Time	—	30 mS	—	Typical @ 277Vac Input, Output Full load.

Environmental Specifications

Parameter	Min.	Typ.	Max.	Notes/Conditions
Case Temperature (T _c)	-30 °C	—	+90 °C	Measured at location specified on case.
Operating Temperature (T _a)	-30 °C	—	+60 °C	This is a reference range. T _c controls temperature range.
Storage Temperature (T _s)	-40 °C	—	+85 °C	Non operating temperature range.
Operating Humidity	—	—	95% RH	Relative Humidity, non-condensing.
Vibration	5 Hz	—	55 Hz	2G, 10 minutes/1 cycle, period 30 minutes, each along X, Y, Z axis.
MTBF	342,000 Hours	—	—	MIL-HDBK-217F Notice 2, T _a = 25C, Output Full Load.

Protection Specifications

Parameter	Min.	Typ.	Max.	Notes/Conditions
Output Short Circuit (SCP)	—	—	—	No Damage, Auto recovery after short is removed.
Output Over Current (OCP)	—	—	+8% I _o	Constant Current Limiting circuit.
Output Over Voltage (OVP)	—	—	120% V _o	No Damage, Auto recovery after fault is removed.
Over Temperature (OTP)	100 °C	105 °C	110 °C	Hick-up mode. Off if T _c reaches \approx 105C, On when T _c reaches \approx 65C

40W**LDHL40W Series****UL TYPE HL****LED Optimized Drivers**

40 Watt - LDHL40W Series

CONSTANT CURRENT LED DRIVER FOR HAZARDOUS LOCATIONS

Safety Compliance

Safety	Notes/Standards
UL/CUL (TYPE HL Rated)	UL8750, UL1310 for UL Class 2 & CAN/CSA C22.2 No. 250.13, UL Type HL
CE	EN61347-1, EN61347-2-13
Withstand Voltage	Input to Output: 3750 Vac
Isolation Resistance	Input to Output: >100 MΩ, 500VDC @ 25 °C, 70 % RH
Dimming Circuit	Dim+ Purple/Dim- Grey are considered part of the secondary circuit.

EMC Compliance

Standard	Notes/Conditions
FCC, 47CFR Part 15	Class B
EN 55015	Limits and methods of measurement of radio disturbance characteristics of electrical lighting and similar equipment.
EN 61000-3-2	Part 3-2: Limits for harmonic current emissions Class C, $\geq 80\%$ Rated Power
EN 61000-3-3	Part 3-3: Limitation of voltage changes, voltage fluctuations and flicker.
EN 61000-4-5	Part 4-5: Surge Immunity test, 2 kV L-N, 4 kV L-FG & N-FG
Energy Star	Energy Star transient protection: Ballast or driver shall comply with ANSI/IEEE C62.41.1-2002 and ANSI/IEEE C62.41.2-2002, Category A operation. The line transient shall consist of seven strikes of a 100 kHz ring wave, 2.5 kV level, for both common mode and differential mode.

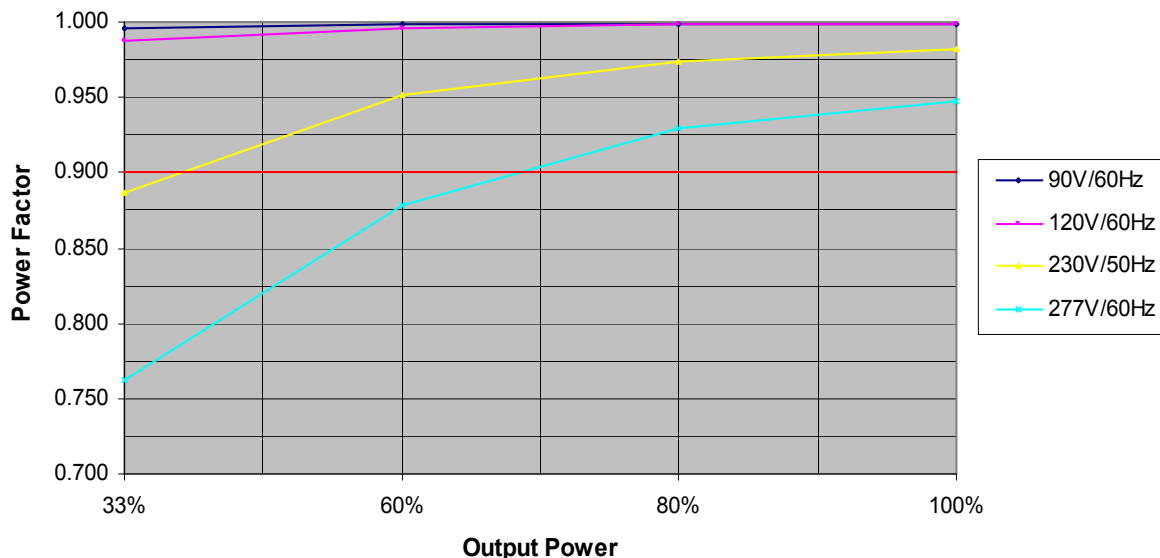
Power Factor Curves (Typical)**PF vs. Output Power**

THD Curves (Typical)

THD vs. Output Power

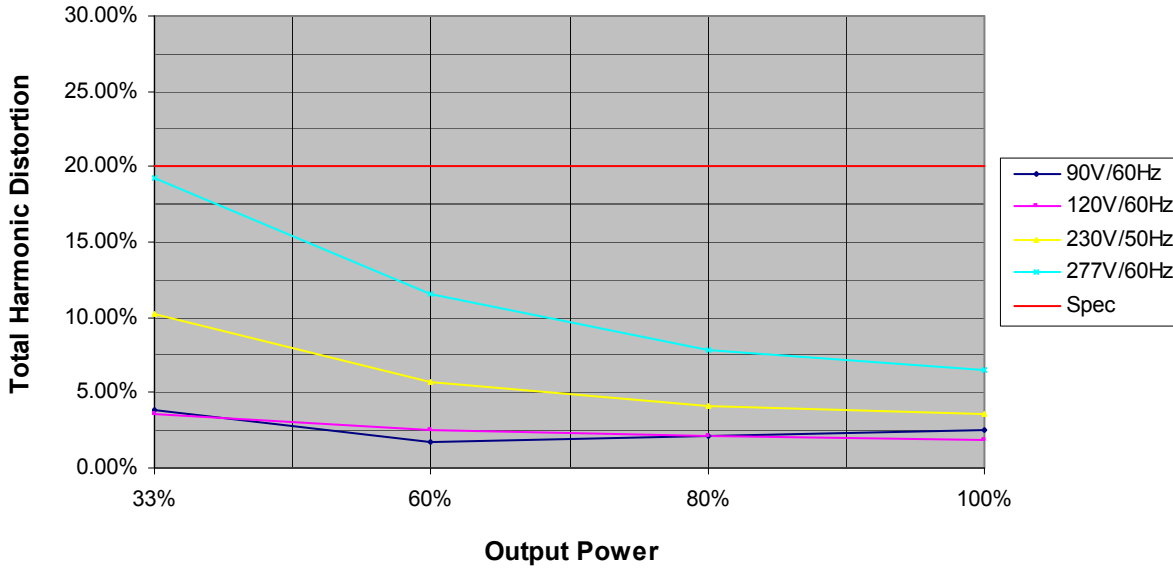

Efficiency Curve (Typical) LDHL40W-36-C1100-RD

Efficiency vs. Output Power

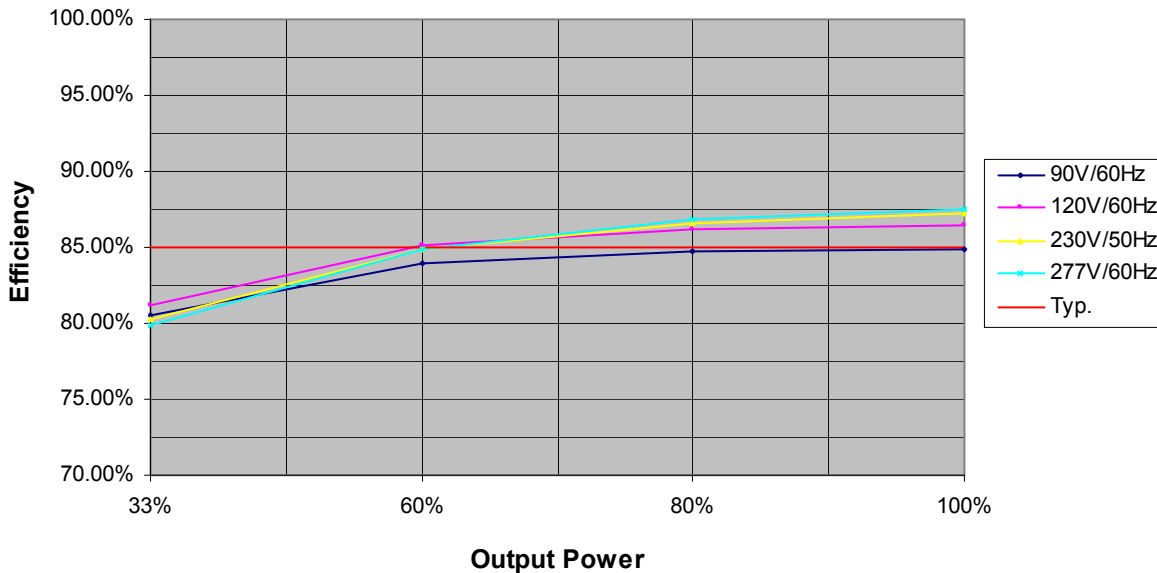

40W

LDHL40W Series

UL TYPE HL



LED Optimized Drivers

40 Watt - LDHL40W Series

CONSTANT CURRENT LED DRIVER FOR HAZARDOUS LOCATIONS

Life vs. Ambient Temperature

LDHL40W Estimated Life Full Load @ 120Vac

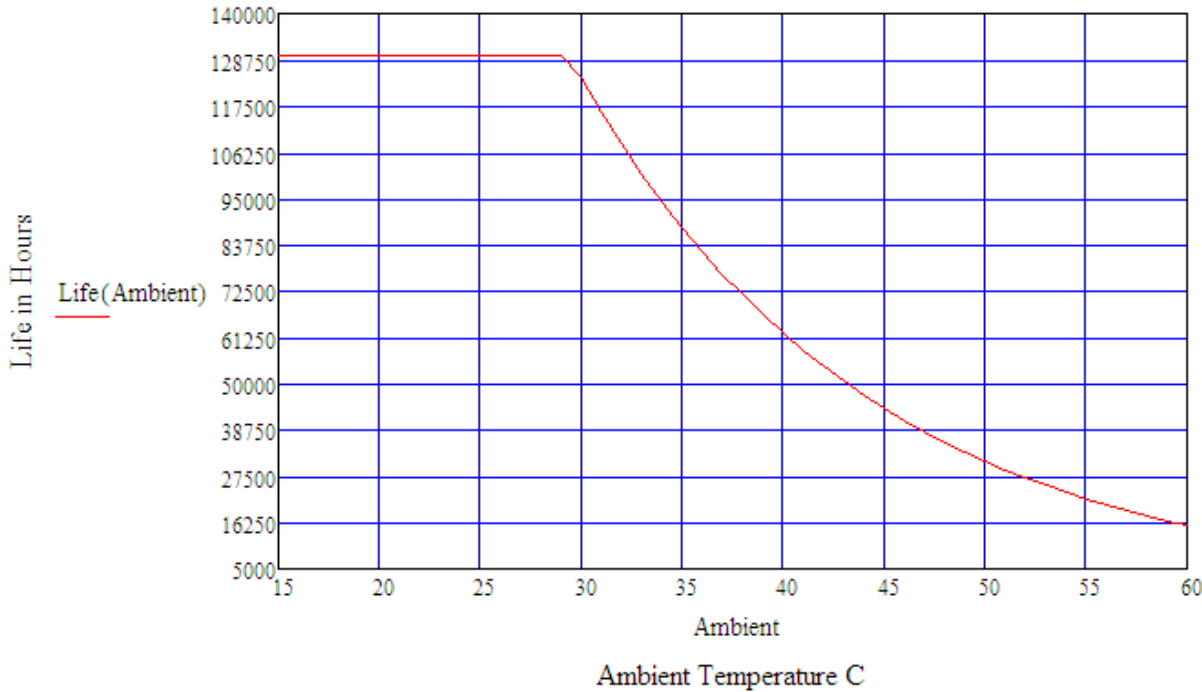

Life vs. Case (Tc) Temperature

LDHL40W Estimated Life Full Load @ 120Vac

